

# CANTER 4.0t

**FE85P**  
4x2 Diesel

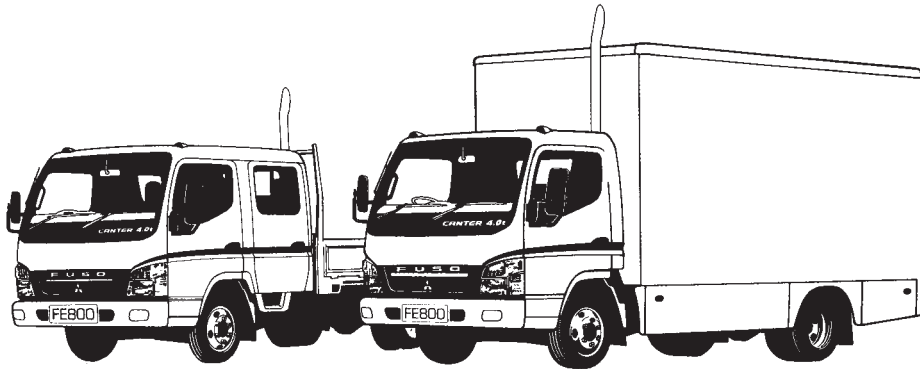

MODEL	W/Base	GVM	GCM
FE85PE6SRFAA mwb	3350mm	7500kg	11000kg
FE85PG6SRFAA lwb	3850mm	7500kg	11000kg
FE85PGWSRFAA lwb Crew Cab	3850mm	7500kg	11000kg

## ENGINE

**Mitsubishi 4D34-3AT3B Diesel (ADR 80/00)**  
 Configuration: 4 Cyl. In-line OHV  
 Type: Turbocharged and Intercooled with Quick Heat Glow Plugs and Catalytic Converter  
 Displacement: 3907cc  
 Bore x Stroke: 104 x 115mm  
 Power (ECE R85-00): 103kW @ 2900 rpm  
 Torque (ECE R85-00): 365Nm @ 1600 rpm  
 Maximum Engine Speed: 3400 rpm  
 Compression Ratio: 18.0:1  
 Oil Cooler: Plate Type, Water Cooled

## FUEL

Pump: MD-TICS (pre-stroke control) In-line Type  
 Governor: RED-III Electronic  
 Controls: Key Operated Start/Fuel, Engine Idle and Engine Emergency Stop  
 Filtration: Main Filter and Water Separator  
 Fuel Capacity: 125 Litres  
 Air Cleaner: Dry Paper Element with Vertical Intake

## COOLING

Fan: 430mm dia. 8 Blades  
 Fan Drive: Thermo Modulated  
 Radiator: Corrugated Fin with Expansion Tank

## ELECTRICAL

Voltage: 12V Negative Earth  
 Alternator Capacity: 12V-100 amp  
 Starter Capacity: 12V-3.0kW  
 Battery Capacity: 2x12V, 110Ah/20hr in Parallel  
 Headlamp: 2x55/60W Quartz Halogen

## CLUTCH

**Mitsubishi C4W30D**  
 Disc Diameter: 300mm  
 Type: Single Dry Plate  
 Operation: Hydraulic with Direct Power Cylinder  
 Facing - Area: Asbestos Free - 846cm<sup>2</sup>

## TRANSMISSION

**Mitsubishi M035S5**  
 No. of Speeds: 5 with In-Dash Gearshift Control  
 Synchronesh: 2nd~5th  
 Ratios - 1st: 5.380  
 - 2nd: 3.028  
 - 3rd: 1.700  
 - 4th: 1.000  
 - 5th: 0.722  
 - Rev. 5.380  
 PTO Opening: LH Side

## PROPELLER SHAFT

Type: P3  
 Universal Joint: Needle Roller

## FRONT AXLE

Type: Reverse Elliot '1' Beam  
 Capacity - Axle: 2900kg  
 Max. Axle Load Rating at Ground: 2900kg

## REAR AXLE

**Mitsubishi D035H**  
 Type: Full Floating Hypoid  
 Capacity - Axle: 5640kg  
 Max. Axle Load Rating at Ground: 5640kg  
 Ratio: 5.714:1

## STEERING

Type: Integral Power Assisted Ball and Nut  
 Ratio: 22.7:1  
 Steering Wheel: 400mm Urethane  
 Steering Column: Tilt/Telescopic Adjustable with Lock

## BRAKES

Type: Vacuum Assisted Hydraulic Dual Circuit with ABS (anti-lock braking system) and Automatic Brake Adjustment  
 Size - Front: 320x110mm  
 - Rear: 320x110mm  
 Lining - Area/Swept: Asbestos Free - 2992/4425cm<sup>2</sup>  
 Park Brake: Transmission Mounted  
 Auxiliary: Exhaust Brake  
 Vacuum Reservoir Capacity: 4.0 Litres

## FRONT SUSPENSION

Type: Long Taper Leaf with Stabiliser Bar  
 Size: 1200x70x14mm-1 Leaves  
 15mm-2  
 Capacity at Ground: 1500kg ea.  
 Shock Absorbers: Double Acting

## REAR SUSPENSION

Type: Semi-Elliptic Leaf with Stabiliser Bar  
 Size: 1250x70x11mm-5 Leaves  
 10mm-1  
 Auxiliary: 990x70x9mm-2 Leaves  
 10mm-4  
 9mm-1  
 Capacity at Ground: 3200kg ea.  
 Shock Absorbers: Double Acting

## CHASSIS

Type: Reinforced Tapered Channel  
 Size: 193x60x6.0mm  
 Width: 753mm  
 Tensile Strength: 440 MPa

## WHEELS & TYRES

Wheel - Type: 7, Single Piece Disc  
 - Size: 17.5x6.00DC-127-9t  
 - Stud Pattern: 6x222.25mm PCD  
 Tyre - Size: 215/75R17.5LT 124/123L  
 Spare Tyre Carrier: Provided

## OPTIONAL EQUIPMENT

H31: (GW. only): 4495/7995kg GVM/GCM Rating  
 R36: Driver's Air Bag & Seat Belt Pre-Tensioner

## MASS (kg - estimated)

Model	Front	Rear	Total
FE85PE6SRFAA	1685	800	2485
FE85PG6SRFAA	1700	805	2505
FE85PGWSRFAA	1820	910	2730

Note: Mass (est.) includes oil and water but excludes spare wheel, tools and fuel.

## CAB FEATURES

### All Steel Forward Control (ECE R29)

Type:	E, G, Manual Tilt 45° GW, Fixed
Mounting:	E, G, Hydroelastic 4 Point GW, Isolated Rubber 6 Point
Colour:	Natural White
Interior:	Fully Trimmed
Windscreen:	Laminated Tinted
Windscreen Wipers:	2 Speed - Intermittent Cycle with Integrated Washer Nozzles
Rear Vision Mirrors:	1 x Internal 2 x External Convex (ECE R46) - Heated
Seating Capacity:	E, G, 3 GW, 7
Seat Belts:	E, G, 2 ELR Lap Sash, 1 Lap GW, 4 ELR Lap Sash, 3 Lap
Seats	<u>Driver:</u> - 228mm Sliding - 47° Reclining - Headrest and Fabric Trim <u>LH:</u> - Flat Folding, 2 Passenger Bench Type with Reclining Adjustment - LH Headrest and Fabric Trim <u>Rear GW:</u> - Bench Type - Low Back with Fabric Trim

## INSTRUMENTS

### Gauges:

- Speedometer with Odometer and Dual Tripmeter
- Tachometer
- Fuel Level, Water Temperature

### Warning Lamps:

- High Beam
- Turn Signal/Hazard Warning
- Park Brake/Brake Dual Circuit
- Exhaust Brake, Low Vacuum, ABS
- Engine Pre-Heat
- Alternator
- Low Oil Pressure
- Engine Control (ECU)
- Heated Mirrors
- SRS Air Bag (R36 opt. only)

## STANDARD EQUIPMENT

- Electric Windows (front only)
- Keyless Central Locking
- Door Side Impact Beams (front only)
- Tinted Side and Rear Glass
- **Air Conditioner/Heater Demister**
- AM/FM ETR Radio with CD Player and Digital Clock
- Dash Storage Tray, 2 DIN Glove Compartment
- RH Overhead, Map and Door Storage Pockets
- Floor Console, LH Seat Back Trays
- Cup Holders (2)
- Coat Hooks (except GW)
- Interior Sun Visors
- Fluorescent Cabin Lamp (except GW)
- Interior Dome Lamp with Delay Function
- Front End-Outline Marker Lamps
- Cigar Lighter
- Engine Access Panel
- Roof Mounting Points  
(except GW - max. static load 50kg)
- Electric Horn
- Reverse Warning Buzzer
- Tool Kit
- Chassis Mounted Tool Box (except GW)
- Vertical Exhaust Outlet

## DIMENSIONS (mm)

		FE85PE 6SRFAA	FE85PG 6SRFAA	FE85PGW SRFAA	
Width	Front Fender:	1995	1995	1995	
	Rear Axle:	2035	2035	2035	
	Front Track:	1665	1665	1665	
	Rear Track:	1560	1560	1560	
	Frame:	753	753	753	
	Max. Body Width - General Application:	2335	2335	2335	
	Length	A Overall:	6015	6735	6735
		C Front Overhang:	1145	1145	1145
		D Wheelbase:	3350	3850	3850
		G Front Axle to Rear of Cab:	525	525	1525
H Rear of Cab to Vertical Exhaust:		121	121	131	
I Frame, Exhaust to Rear Axle:		2704	3204	2194	
J Frame, Rear Axle to End:		1480	1700	1700	
Height	N Overall:	3240	3240	2705	
	P Cab to Ground:	2190	2190	2255	
	Q Cab to Frame:	1514	1514	1514	
	R Rear Frame to Ground:	775	775	770	
	Ground Clearance:	185	185	185	

## PERFORMANCE (Calculated - Paved Road)

Road Speed (km/h) at Max. Engine Speed:	117	117	117
Gradeability at Rated GVM:	39.2%	39.2%	39.2%
Gradeability at Rated GCM:	25.4%	25.4%	25.4%
Turning Circle (kerb to kerb):	12.0m	13.6m	13.6m

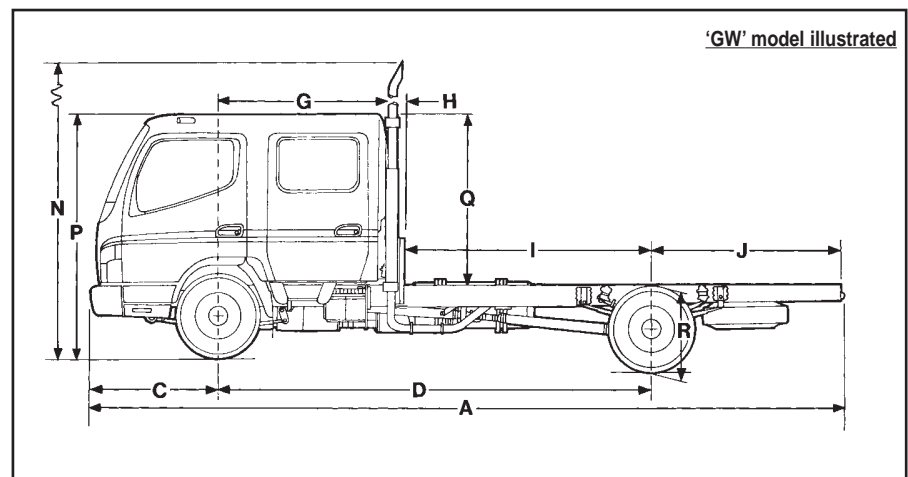
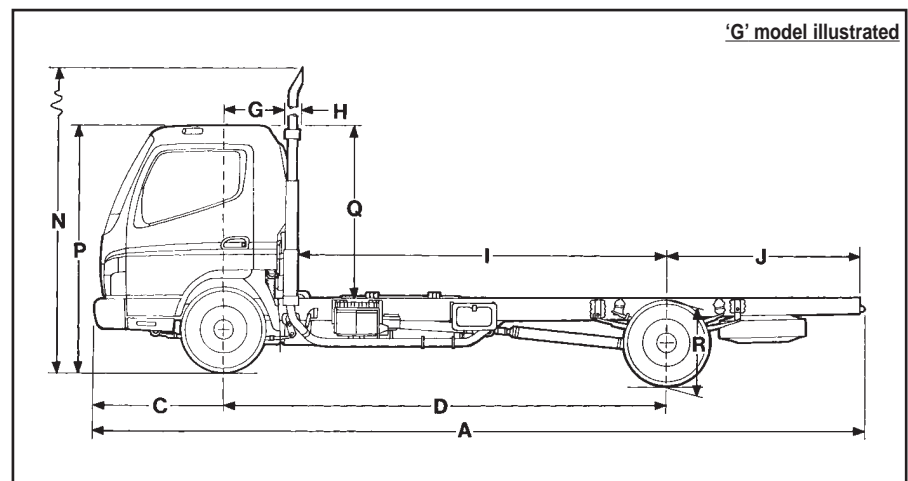

Note: Chassis reinforcement must be utilised for Tipper/Demountable type body configurations.

To conform with ADR 13/.. and 14/.. (lighting/mirror requirements) the following must be adhered to at body installation.

- If overall width exceeds 2.1 metres and other than a flat type or tipper body is fitted, rear end-outline marker lamps must be installed.
- If overall length exceeds 6.0 metres, side reflectors must be installed.
- If overall width exceeds 2.1 metres and length exceeds 7.5 metres, side marker lamps must be installed.
- If overall width is less than 2.2m, the mirrors must be modified to project not more than 230mm.