

# FIGHTER 10.0

**FM65/7F**  
177kW 4x2

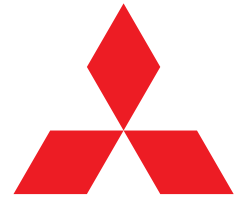

## FUSO

MODEL	W/Base	GVM	GCM	
FM65FH1RFAE swb 6 spd	4280mm	16000kg	25000kg	} Steel Rear Suspension
FM65FJ1RFAG mwb Auto	4620mm	16000kg	25000kg	
FM65FP1RFAE xlwb 6 spd	6080mm	16000kg	25000kg	
FM67FP1RFAH xlwb 6 spd	6080mm	16000kg	25000kg	Air Rear Suspension

### ENGINE

**Mitsubishi 6M60-1AT1 Diesel (ADR80/00)**  
 Configuration: 6 Cyl. In-line OHC, 4-Valve  
 Type: Turbocharged with Air to Air Intercooler, Common Rail Fuel System and Catalytic Converter  
 Displacement: 7545cc  
 Bore: 118mm  
 Stroke: 115mm  
 Power (ECE R85-00): 177kW @ 2600 rpm  
 Torque (ECE R85-00): 686Nm @ 1400 rpm  
 Maximum Engine Speed: 2900 rpm  
 Compression Ratio: 17.8:1  
 Oil Cooler: Plate Type, Water Cooled

### FUEL

Injection System: DENSO Common Rail System  
 Governor: Electronic, Speed Limited to 100 km/h  
 Controls: Key Operated Start/Fuel Engine Idle Emergency Stop  
**Cruise Control** (range 40-100 km/h)  
 Filtration: Main Filter and Water Separator  
 Fuel Capacity: 185 Litres  
 Air Cleaner: Dual Element Cyclopac with Vertical Intake and Air Restriction Indicator

### COOLING

Fan: 520mm dia. 6 Blades  
 Fan Drive: Thermo Modulated  
 Radiator: Corrugated Fin with Expansion Tank

### ELECTRICAL

Voltage: 24V Negative Earth  
 Alternator Capacity: 24V-50 amp  
 Starter Capacity: 24V-5.0kW  
 Battery Capacity: 2x12V, 65Ah/20hr  
 Headlamp - Type: Quartz Halogen Multi Parabola  
 - Capacity: Low Beam 2x70W High Beam 4x70W

### CLUTCH

**Mitsubishi C7M38 (except FM65FJ auto)**  
 Disc Diameter: 380mm  
 Type: Single Dry Plate  
 Operation: Air Assisted Hydraulic  
 Facing - Area: Cerametallic - 638.4cm<sup>2</sup>

### TRANSMISSION (Manual)

**Mitsubishi M070S6-D**  
 No. of Speeds: 6 with Air Assisted Gearshift  
 Synchronesh: 2nd-6th  
 Ratios - 1st: 8.064  
 - 2nd: 5.443  
 - 3rd: 3.064  
 - 4th: 1.824  
 - 5th: 1.321  
 - 6th: 1.000  
 - Rev. 7.354  
 PTO Opening: LH Side

### TRANSMISSION (FM65FJ Auto)

**Allison MD3060P**  
 No. of Speeds: 6  
 Control: Electronic Lever Type with Service Brake Interlock and Exhaust Brake Interface  
 Oil Cooler: Oil to Air  
 Torque Converter: TC415-2.35 with Lockup Clutch  
 Ratios - 1st: 3.487  
 - 2nd: 1.864  
 - 3rd: 1.409  
 - 4th: 1.000  
 - 5th: 0.750  
 - 6th: 0.652  
 - Rev. 5.027  
 PTO Opening: LH & RH Engine Driven

### PROPELLER SHAFT

Type: P10  
 Universal Joint: Needle Roller

### FRONT AXLE

**Mitsubishi F070T**  
 Type: Reverse Elliot '1' Beam  
 Capacity - Axle: 6000kg  
 Max. Load Rating at Ground: 6000kg

### REAR AXLE

**Mitsubishi R060T/D8H**  
 Type: Full Floating Hypoid  
 Capacity - Axle: 10200kg  
 Max. Load Rating at Ground: 10000kg  
 Ratio: FM65FH. 5.142:1  
 FM65FJ. 6.666:1  
 FM65/7FP. 4.444:1

### STEERING

Type: Integral Power Assisted Ball and Nut  
 Ratio: 22.4:1  
 Steering Wheel: 450mm Urethane  
 Steering Column: Tilt/Telescopic Adjustable with Lock

### BRAKES

Type: Full Air, Dual Circuit, Mitsubishi Taper Roller with Automatic Brake Adjustment  
 Size - Front: 410x150mm  
 - Rear: 410x200mm  
 Lining - Area/Swept: Asbestos Free - 5820/9020cm<sup>2</sup>  
 Park Brake: Rear Wheel Spring Actuated  
 Auxiliary: Exhaust Brake  
 Compressor: Water Cooled, 340cc Single Cyl.  
 Air Dryer Model: DU-5

### FRONT SUSPENSION

Type: Parabolic Leaf  
 Size: 1400x80x19mm-4 Leaves  
 Capacity at Ground: 3400kg ea.  
 Shock Absorbers: Double Acting

### REAR SUSP. (FM65 - Steel)

Type: Semi-Elliptic Leaf  
 Size: 1400x80x11mm-10 Leaves  
 Auxiliary: 960x80x11mm-10 Leaves  
 Capacity at Ground: 5100kg ea.

### REAR SUSP. (FM67 - Air)

Type: Trailing Arm with Air Dump Control  
 RFCN: RF2043  
 Trailing Arm: (615+380)x80x35mm-2 Leaves  
 Capacity at Ground: 10000kg total  
 Shock Absorbers: Double Acting

### CHASSIS

Type: Parallel Channel  
 Size: 280x90x8.0mm  
 Width: 840mm  
 Tensile Strength: 55kg/mm<sup>2</sup>

### WHEELS & TYRES

Wheel - Type: 7, Single Piece Disc  
 - Size: 22.5x8.25DC-165-12T  
 - Stud Pattern: 10x335mm PCD  
 Tyre - Size: FM65FH, J. 11R22.5 148/145L  
 H. Traction Tread to Rear  
 FM65/7FP. 275/70R22.5 148/145L  
 Spare Tyre Carrier: Provided

### OPTIONAL EQUIPMENT

R50 (P. only): 370 Litre (2x185) Fuel Capacity

### MASS (kg - estimated)

Model	Front	Rear	Total
FM65FH1RFAE	2705	1760	4465
FM65FJ1RFAG	2820	1870	4690
FM65FP1RFAE	2770	1955	4725
FM67FP1RFAH	2760	1890	4650

Note: Mass (est.) includes oil and water but excludes spare wheel, tools and fuel.

## CAB FEATURES

### All Steel Forward Control

Type:	Manual Tilt 44 deg.
Mounting:	Hydroelastic Suspension 4 Point
Colour:	Natural White
Interior:	Fully Trimmed
Windscreen:	Laminated Tinted
Windscreen Wipers:	2 Speed - Intermittent Cycle
Rear Vision Mirrors:	RH. Heated LH. Remote/Heated with Convex Spotter
Seating Capacity:	3
Seat Belts:	2 ELR Lap Sash, 1 Lap
Seats	<u>Driver:</u> - Air Suspension with Auto Levelling Height Control - 32 Stage Reclining - 11 Stage Sliding - Front and Rear Height Adjuster - Lumbar Support - Integral Headrest and Fabric Trim <u>Centre:</u> - Low Back with Fabric Trim - Forward Folding <u>LH:</u> - Fixed Base - 32 Stage Reclining - Integral Headrest and Fabric Trim

## INSTRUMENTS

### Gauges:

- Speedometer with Odometer and Dual Tripmeter
- Tachometer
- Air Pressure (2)
- Fuel Level
- Water Temperature
- Digital Clock

### Warning Lamps:

- Turn Signal
- High Beam
- Exhaust Brake
- Park Brake
- Alternator
- Oil Filter Blockage
- Engine/Cruise Control (ECU)
- Air Filter Restriction
- Door
- Cab Tilt

### Warning Lamp/Buzzer:

- Air Pressure
- Oil Pressure
- Engine Overheat/Low Coolant Level
- Air Rear Suspension (FM67. only)
- Transmission Oil Temperature (J. only)

## STANDARD EQUIPMENT

- Electric Windows and Central Locking
- Tinted Side and Rear Glass
- **Air Conditioner/Heater Demister**
- AM/FM ETR Radio with Cassette and CD Player
- Centre Seat Storage Console
- LH Seat Storage Tray
- Overhead Storage Pocket with Lid
- RH Door Storage Pocket
- Rear Bunk Storage Pockets
- Cup Holders (2)
- Opening Rear Quarter Windows
- Interior Sun Visors
- Fluorescent Cabin Lamp
- Interior and Map Reading Lamps
- Windscreen Washers
- Hazard Warning Lamps
- Front End-Outline Marker Lamps
- Cigar Lighter
- Roof Mounting Points (max. static load 50kg)
- Electric Horn
- Reverse Warning Buzzer
- Tool Kit
- Chassis Mounted Tool Box
- Vertical Exhaust Outlet

## DIMENSIONS (mm)

		FM65FH 1RFAE	FM65FJ 1RFAG	FM65/7FP 1RFAE/H
Width	Front Fender:	2370	2370	2370
	Rear Axle:	2435	2435	2435
	Front Track:	1915	1915	1915
	Rear Track:	1815	1815	1815
	Frame:	840	840	840
Length	A Overall:	7455	7945	10695
	C Front Overhang:	1245	1245	1245
	D Wheelbase:	4280	4620	6080
	G Front Axle to Rear of Cab:	745	745	745
	H Rear of Cab to Vertical Exhaust:	210	210	210
	I Frame, Exhaust to Rear Axle:	3325	3665	5125
	J Frame, Rear Axle to End:	1930	2080	3370
Height	N Overall - FM65:	3410	3405	3360
	- FM67:			3350
	P Cab to Ground - FM65:	2685	2680	2635
	- FM67:			2630
	Q Cab to Frame:	1654	1654	1654
	R Rear Frame to Ground - FM65:	1080	1075	1035
	- FM67 Suspension - Inflated:			969
	- Delfated:			920
	Ground Clearance:	265	265	220

## PERFORMANCE (Calculated - Paved Road)

Electronically Speed Limited to (km/h):	*100	*100	*100
Gradeability at Rated GVM:	33.6%	41.5%	31.5%
Gradeability at Rated GCM:	20.4%	24.9%	19.2%
Turning Circle (kerb to kerb):	15.0m	16.2m	20.8m

\*Conforms to ADR 65/..

'FM65FH' model illustrated

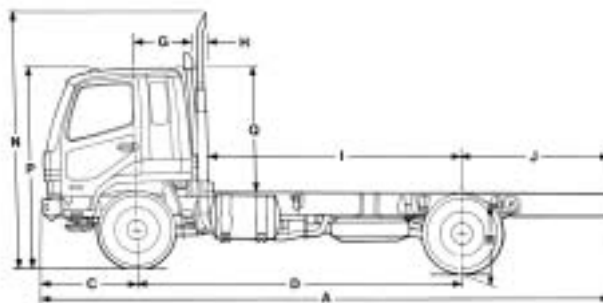

'FM65FP' model illustrated

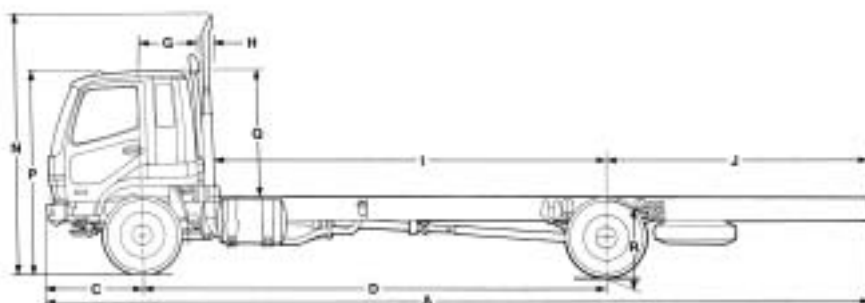

Note: Chassis reinforcement must be utilised for Tipper/Demountable type body configurations.

To conform with ADR 13/.. (lighting requirements) the following must be adhered to at body installation.

- Reflective rear marker plates must be installed.
- If other than a flat type or tipper body is fitted, rear end out-line marker lamps must be installed.
- If overall length exceeds 6.0 metres, side reflectors must be installed.
- If overall length exceeds 7.5 metres, side marker lamps must be installed.